



A Robotic and Conventional Automation Manufacturer

# Automatic Palletizing System

Small foot print • Cost effective • Easy to Operate

*"A Model of Simplicity and Strength"*



**Series 200**  
Dual Chamber Palletizer

## Palletize:

**Cases • Bags • Trays**

up to 50 lbs., run speeds up to 45 products per/minute

## RAESCO, Inc.

Robotics and Automated Equipment Services Co.

16 Corporate Circle, East Syracuse, New York 13057

888.432.4578 | Fax 315.432.4579 • [info@raesco.com](mailto:info@raesco.com) | [www.raesco.com](http://www.raesco.com)

**Robotic Cells • Material Handling • Custom Automation**

## Series 100/200 Features

- :: Up to 45 cases or bags per/min.  
(size dependent)
- :: Carbon steel painted or stainless steel construction
- :: Brand name components
- :: Servo control for speed and accuracy
- :: 230/480 v - 3 phase power
- :: WEB server for remote diagnostic or program change
- :: PLC with touch screen control
- :: Easily converts single chamber to dual chamber
- :: Auto product reject system

The RAESCO Series 100/200 is designed to be user friendly. Our patent pending design is a "A Model of Simplicity and Strength".

We offer single chamber units (Series 100) and dual chamber units (Series 200). This cost effective solution uses uncomplicated design principles and reliable brand name components to ensure serviceability and ease of operation.

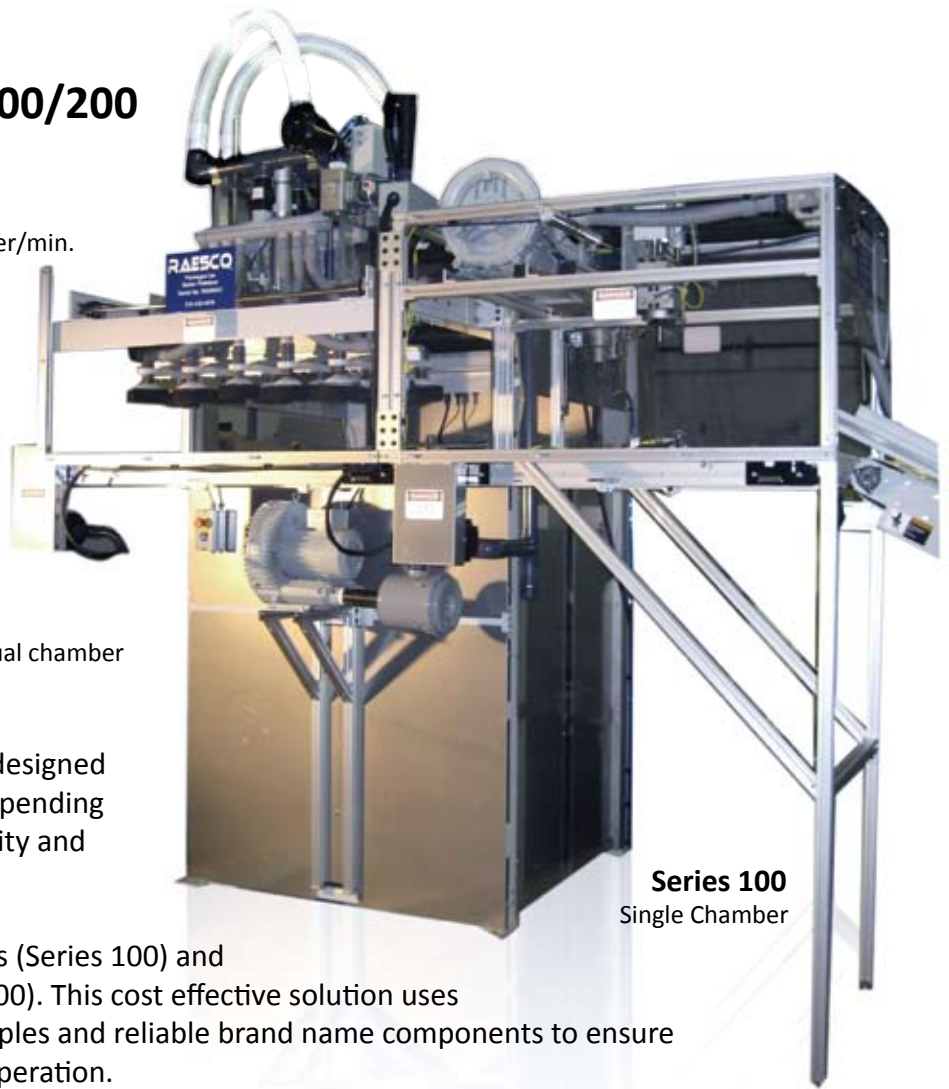

**Series 100**  
Single Chamber



**Series 200 Dual Chamber Palletizer**



**Positive inclines to product index**



**Keep Production  
running during  
pallet change**

## Series 100/200 Features



### Safety

- :: ANSI/OSHA Approved
- :: Lock Out/Tag Out
- :: Completely Safe Guarded
- :: Multiple E-Stops



### Color Touch Screen Control

- :: Diagnostics
- :: Layer and Pattern Setup
- :: Product change
- :: I/O Manual Control
- :: Production Statistics
- :: Password Protected



### Robust Construction

- :: Stainless Steel
- :: Powder Coated Carbon Steel
- :: UHMWPE or STSTL where product makes contact
- :: Grade 8 Fasteners

### Servo Control Index System

- :: Precision
- :: Speed
- :: Reliability
- :: Top Quality Conveyors

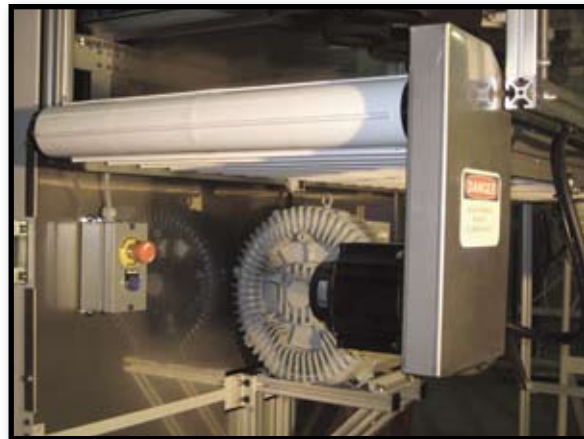

16 Corporate Circle, East Syracuse, New York 13057  
888.432.4578 | Fax 315.432.4579  
info@raesco.com | www.raesco.com

Robotic Cells • Material Handling • Custom Automation



RSC Cases

## Palletizer Features

- :: 40 x 48 GMA or Chop Pallets
- :: Manually remove pallet and replace
- :: Series 200 - production never stops
- :: Series 100 - pallet change 1-2 minutes
- :: Load walls expand and retract for tight pallet load
- :: Small Foot Print, 100-200 Square/Feet
- :: Cost effective, quick return on investment
- :: Air: 100 PSI at 10 scfm
- :: Servo control for speed and accuracy



Wood Pellets



Packaged Ice

## Palletize up to 1 ton per/pallet

- :: Bags
- :: Cases
- :: Trays
- :: Shrink Bundles

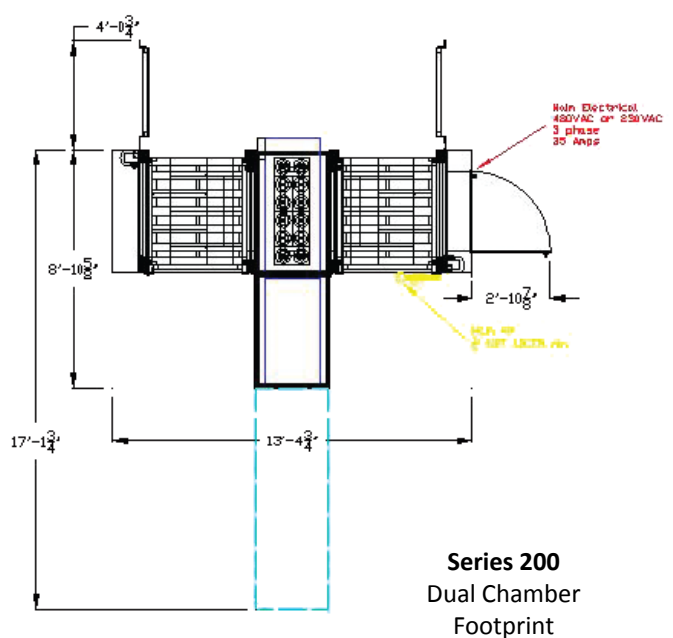
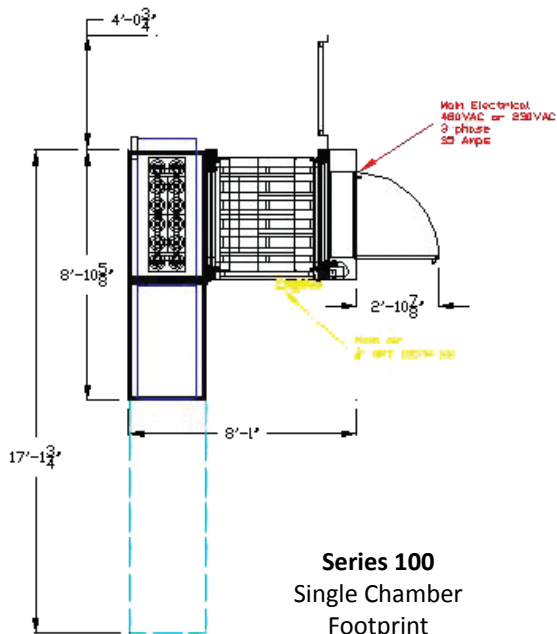

Ask about our optional automatic pallet handling systems